

Servicing & Checking

- It is recommended the Tempering Valve be checked annually by a registered plumber to ensure correct functioning of the valve.
- Where the water supply is of poor quality or any other supply variations are likely, it may be necessary to check the Tempering Valve at more frequent intervals.

Trouble Shooting

What is wrong!	Causes	How to fix it
No flow from valve	No or low water supply at inlets	Check inlet pressures and flows Restore inlet supply pressure
Fluctuating or low flow rate	Fluctuating or incorrect supply pressures	Ensure inlet supply pressures are balanced May require Pressure Limiting Valves on inlets
Outlet temperature unstable or varying over time	Fluctuating or low temperature hot water supply Fluctuating or incorrect supply pressures	Check and adjust hot water supply temperature and pressure
Outlet temperature cannot be adjusted	Valve installed with inlets reversed	Install valve as shown in instructions and re-adjust outlet temperature
Noise	High water velocity	Reduce water velocity Limit inlet pressure

Spare Parts

- No spare parts are available for this valve.
- This valve is a safety valve and cannot be serviced. If the valve fails to operate, it is to be replaced.
- No attempt should be made to dismantle the valve. Any attempt to dismantle the valve (other than anti-tamper cap) will void all warranties.

Methven warrants this product against manufacturing defects and that it is suitable for use under the general operating conditions specified in this instruction sheet. However, regional regulations apply and may affect your warranty. Please refer to www.methven.com or call customer service for full details.

New Zealand
0800 804 222

Australia
1300 638 483

UK
0800 195 1602

285049

www.methven.com

ISSUE A

TEMPERING VALVE (NTV-L) Installation Guide

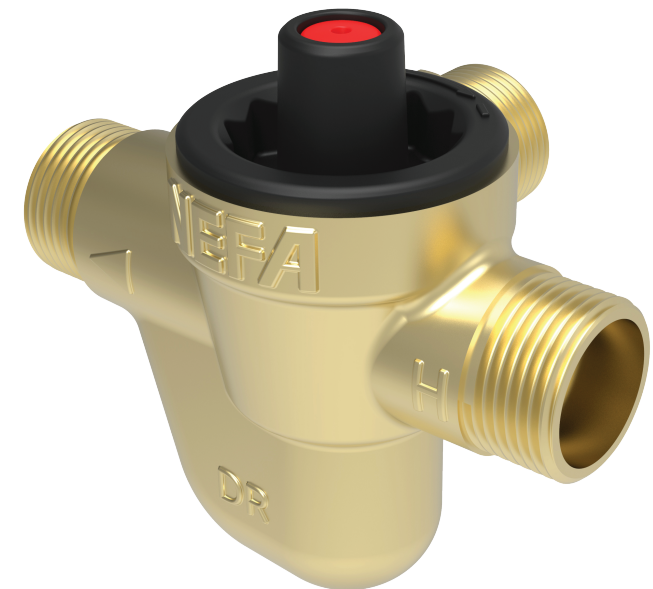

methven.com

NEFA
BY METHVEN

Technical Specifications:

- 20mm (3/4" BSP) male connections
- Recommended outlet temperature range: 45°C to 55°C¹
- Factory setting (must be commissioned on site): 50°C or 55°C nominal²
- Accuracy of mixed outlet temperature: $\pm 3^\circ\text{C}$
- Cold water supply: 5°C to 25°C
- Hot water supply: 60°C to 90°C³
- Hot water / mixed water temperature differential: 15°C minimum
- Supply pressure – static: 1600kPa maximum
- Supply pressure – dynamic: 20kPa min - 500kPa max
- Maximum permitted pressure variations at either inlet (from supply pressure at commissioning): $\pm 10\%$ maximum^{4,5,6}
- Minimum flow rate: 4 litres/minute

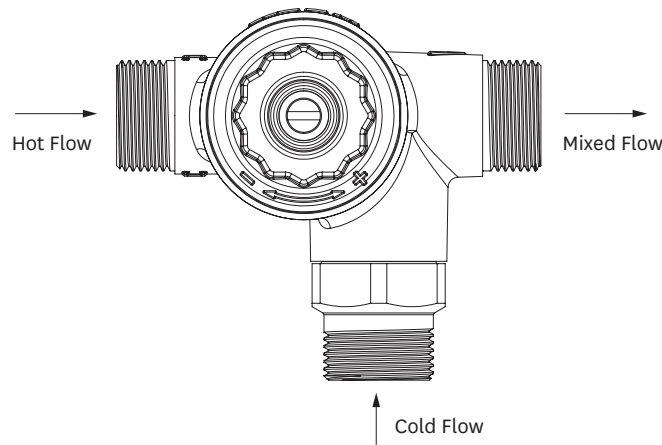

Notes:

1. The valve can be set as low as 35°C or as high as 58°C, depending on site conditions. The temperatures are outside the optimum working range of the valve and the requirements of NZBC G12.
2. As specified on label on box.
3. The NZ Building Code acceptable solution G12/AS1 clause 6.14 states that water shall be stored at not less than 60°C to inhibit the growth of legionella bacteria. To obtain good tempering valve response, the cylinder thermostat should be set at a minimum of 65°C.
4. The maximum permitted pressure variation in either supply from commissioning pressures in order to maintain the outlet temperature to $\pm 3^\circ\text{C}$.
5. Steps should be taken to eliminate any causes of rapid changes in supply pressures, as this may result in an outlet temperature spike greater than $\pm 3^\circ\text{C}$ from commissioned temperature. If a spike occurs, it may take a few seconds for the temperature to stabilise back to within $\pm 3^\circ\text{C}$.
6. The maximum ratio permitted between supply pressures, under dynamic flow operation. It is recommended at time of commissioning that hot and cold pressures be as equal as possible.

Operation

- The Tempering Valve is designed to accurately provide safe controlled temperature water for outlets primarily used for personal hygiene. The Tempering Valve will maintain the outlet mixed temperature to $\pm 3^\circ\text{C}$ from set temperature.
- If the cold water supply to the valve fails, the valve will automatically shut off the hot water supply preventing scalding. 15°C differential between the hot inlet water temperature and outlet set temperature is required to ensure effective hot water shut off.
- Optimum performance of the valve is obtained when the hot and cold dynamic supply pressures (flowing) are equal. Static supply pressures (non-flowing) will not give a true indication of dynamic pressures.
- In a domestic installation, it is recommended that one Nefa Pressure Limiting Valve is used at the property boundary to limit pressure to the whole site.
- Where inlet pressures may be unbalanced, as in commercial installations with separate hot and cold water supply, it is recommended that separate Nefa Pressure Limiting Valves be fitted to both inlets of the Tempering Valve for optimum performance and that an additional check valve be fitted on the hot water supply.
- Not to be used on steam supplied systems.

Valve Adjustment

- Before setting the valve, ensure the hot water source is switched on and supplying water within the specified hot water temperature limits. It is recommended the water heater, if controlled by an adjustable thermostat should be set to the required 15°C differential temperature necessary for thermal shut off.
- Allow the water to flow 1-2 minutes to ensure the mixed water temperature has stabilised.
- A thermometer must be used to test the hot water at the nearest outlet to the installed valve to ensure the correct mixed water temperature is supplied. Test at a flow rate of not less than 4 litres/minute.
- Using a screwdriver, turn the adjustment screw in the direction + (hotter) or - (colder) as indicated on the cover until the required set temperature is achieved.
- Once the set temperature has been reached and tested with a thermometer, the anti-tamper cap can be pushed into place if required.

