

KIRI WALL/CEILING DRENCHER INSTALLATION GUIDE

TECHNICAL SPECIFICATIONS

Operating Pressure:

Min 35 kPa, Max 500 kPa.

Recommended installation of a pressure limiting valve if supply exceeds 500 kPa.

Operating Temperature:

Max 70°C

NB: New Zealand building code clause G12 - water supplies specifies all outlets used primarily for personal hygiene shall deliver water at a safe temperature.

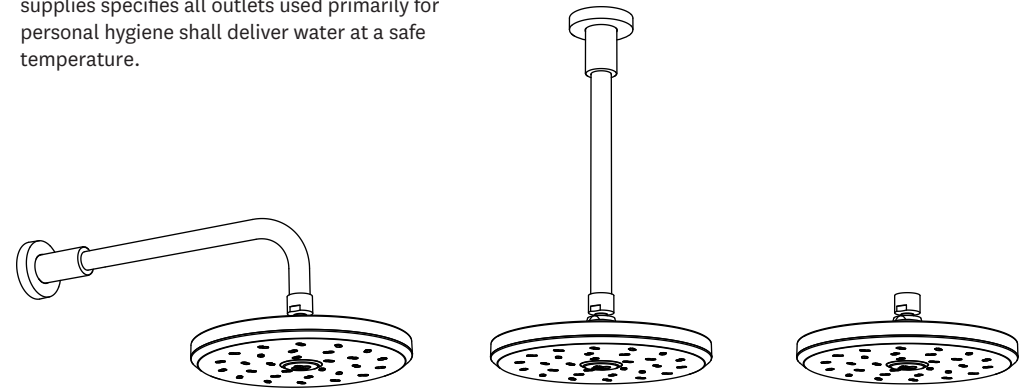

Methven warrants this product against manufacturing defects and that it is suitable for use under the operating conditions specified in this instruction sheet.

For your warranty please refer to www.methven.com or call Customer Service: 0800 804 222



NOTE - If assembling a showerhead to a pre-existing arm skip to step 4

1.
FOR WALL ARM - RECOMMENDED MINIMUM HEIGHT
2100mm FROM FLOOR LEVEL

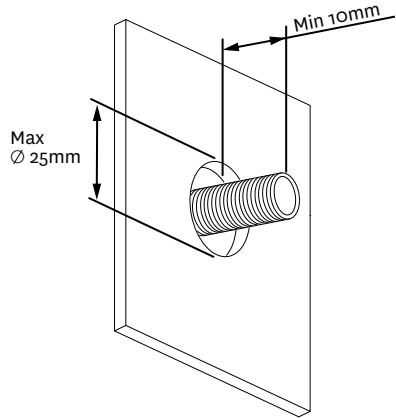

Install a 1/2" male threaded connection at the desired height on wall/or position on ceiling, ensuring that a minimum of 10mm of thread protrudes past the finished wall.

2.

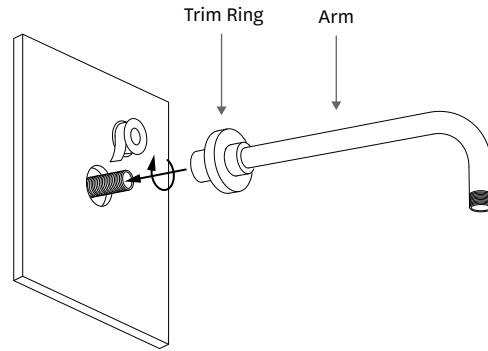

Slide chrome trim ring onto the appropriate end of the arm. Screw the arm onto the 1/2" connection using plumbers tape or similar to ensure a reliable seal.

3.

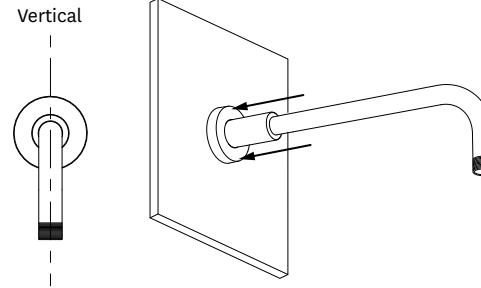

Position the arm vertically and push trim ring into place.

4.

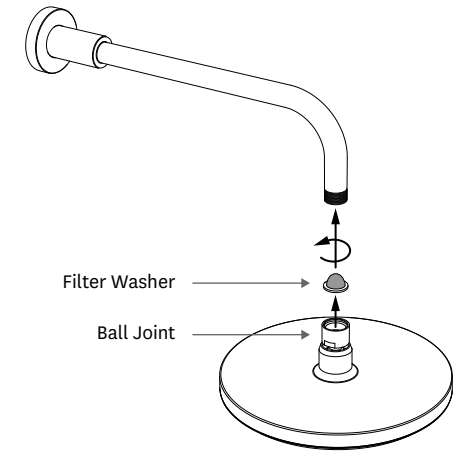

Remove the protective cap from the showerhead ball joint and screw the unit onto the wall/ceiling arm ensuring the filter washer is in place.

5.

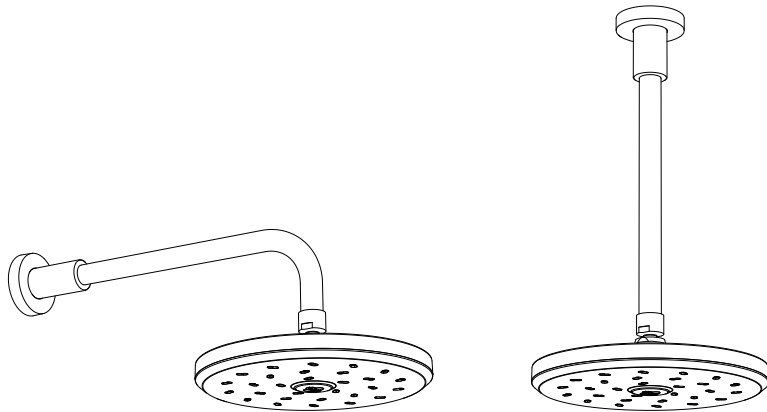

Tilt and rotate the shower head to the desired position.

CLEANING

Water contains lime which remains on the surface after the water has evaporated. These lime deposits can be prevented from forming by wiping immediately after use.

To clean the chrome-plated surfaces use a soft cloth, soap and warm water. Never use cleaning agents that contain a corrosive acid or a scouring additive.

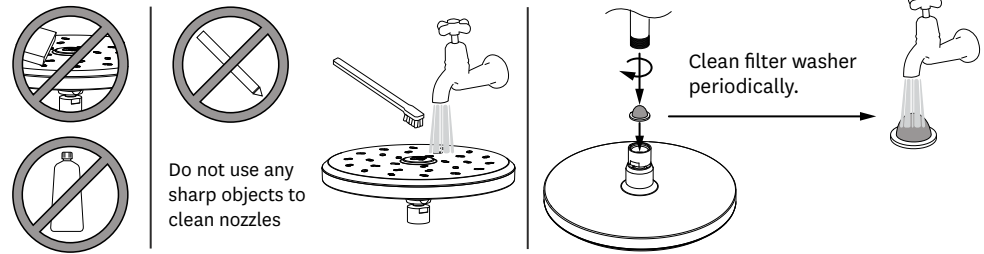

Note: Removal of the flow restrictor in the ball joint may be necessary to optimise flow performance in low or unequal pressure systems only.